

DL-CNN Framework for Medical Image Analysis

Dr. Md. Sameeruddin Khan¹, Dr. GNV Vibhav Reddy¹, P. Anupama¹

¹Department of CSE, Sree Dattha Institute of Engineering and Science, Hyderabad, India.

ABSTRACT

Deep Learning is the newest and the current trend of the machine learning field that paid a lot of the researchers' attention in the recent few years. As a proven powerful machine learning tool, deep learning was widely used in several applications for solving various complex problems that require extremely high accuracy and sensitivity, particularly in the medical field. In general, the brain tumor is one of the most common and aggressive malignant tumor diseases which is leading to a noticeably short expected life if it is diagnosed at a higher grade. Based on that, brain tumor classification is an overly critical step after detecting the tumor in order to achieve an effective treating plan. In this paper, we used Convolutional Neural Network (CNN) which is one of the most widely used deep learning architectures for classifying a dataset of 3064 T1 weighted contrast-enhanced brain MR images for grading (classifying) the brain tumors into three classes (Glioma, Meningioma, and Pituitary Tumor). The proposed CNN classifier is a powerful tool and its overall performance with an accuracy of 98.93% and sensitivity of 98.18% for the cropped lesions, while the results for the uncropped lesions are 99% accuracy and 98.52% sensitivity and the results for segmented lesion images are 97.62% for accuracy and 97.40% sensitivity.

Index terms: Convolutional neural networks, medical image analysis, machine learning and deep learning.

1. INTRODUCTION

Machine learning algorithms have the potential to be invested deeply in all fields of medicine, from drug discovery to clinical decision making, significantly altering the way medicine is practiced. The success of machine learning algorithms at computer vision tasks in recent years comes at an opportune time when medical records are increasingly digitalized. The use of electronic health records (EHR) quadrupled from 11.8% to 39.6% amongst office-based physicians in the US from 2007 to 2012 [1]. Medical images are an integral part of a patient's EHR and are currently analyzed by human radiologists, who are limited by speed, fatigue, and experience. It takes years and great financial cost to train a qualified radiologist, and some health-care systems outsource radiology reporting to lower-cost countries such as India via teleradiology. A delayed or erroneous diagnosis causes harm to the patient. Therefore, it is ideal for medical image analysis to be carried out by an automated, accurate and efficient machine learning algorithm. There is a myriad of imaging modalities, and the frequency of their use is increasing. Smith-Bindman *et al.* [2] looked at imaging use from 1996 to 2010 across six large integrated healthcare systems in the United States, involving 30.9 million imaging examinations. The authors found that over the study period, CT, MRI and PET usage increased 7.8%, 10% and 57% respectively. The symbolic AI paradigm of the 1970s led to the development of rule-based, expert systems. One early implementation in medicine was the MYCIN system by Shortliffe [3], which suggested different regimes of antibiotic therapies for patients. Parallel to these developments, AI algorithms moved from heuristics-based

techniques to manual, handcrafted feature extraction techniques. and then to supervised learning techniques. Unsupervised machine learning methods are also being researched, but most of the algorithms from 2015-2017 in the published literature have employed supervised learning methods,

2. RELATED WORK

Recently, Machine learning (ML) and Deep Learning (DL) methods are widely been used for detection and grading brain tumors using different imaging modalities, especially those acquired using MRI. In this section, the most recent and related research works on the paper topic are presented. Mohsen, Heba, et al. [8] propose a system that combines discrete wavelet transform (DWT) features and deep learning (DL) techniques. They have used fuzzy c-mean method for segmenting the brain tumor, and for each detected lesion the DWT was applied to extract the features, where these features are fed into the principal component analysis (PCA) for feature dimension reduction and finally the selected features are then fed to deep neural networks (DNN). The results show that they achieve an accuracy rate of 96.97% and a sensitivity of 97.0 %. Widhiarso, Wijang, Yohannes Yohannes, and Cendy Prakarsah [10] presented a brain tumor classification system using a convolutional neural network (CNN) and Gray Level Co-occurrence Matrix (GLCM) based features. They extracted four features (Energy, Correlation, Contrast, and Homogeneity) from four angles (0°, 45°, 90°, and 135°) for each image and then these features are fed into CNN, they tested their methodology on four different datasets (Mg-Gl, Mg-Pt, Gl-Pt, and Mg-Gl-Pt) and the best accuracy achieved was 82.27% for Gl-Pt dataset using two sets of features; contrast with homogeneity and contrast with correlation. Seetha, J., and S. S. Raja [12] proposed a deep CNN based system for automated brain tumor detection and grading. The system is based on Fuzzy C-Means (FCM) for brain segmentation and based on these segmented regions a texture and shape features were extracted then these features were fed into SVM and DNN classifiers. The results showed that the system achieved a rate of 97.5% accuracy. On the other hand, Cheng, Jun, et al. [13] enhanced the performance of the brain tumor classification process using region of interest (ROI) augmentation and fine ring-form partition. They applied these enhancements to different feature extractions methods which are intensity histogram, GLCM, and the bag-of-words (BoW) where these features vectors are fed into a classifier. The experimental results showed that the accuracy enhanced from 71.39% to 78.18%, and 83.54% to 87.54%, and 89.72% to 91.28% for intensity histogram, GLCM, and BoW respectively.

3. PROPOSED SYSTEM

Currently, CNNs are the most researched machine learning algorithms in medical image analysis [4]. The reason for this is that CNNs preserve spatial relationships when altering input images. As mentioned, spatial relationships are of crucial importance in radiology, for example, in how the edge of a bone joins with muscle, or where normal lung tissue interfaces with cancerous tissue. As shown in Fig. 1., a CNN takes an input image of raw pixels, and transforms it via Convolutional Layers, Rectified Linear Unit (RELU) Layers and Pooling Layers. This feeds into a final Fully Connected Layer which assigns class scores or probabilities, thus classifying the input into the class with the highest probability. CNNs are currently the most widely used deep-feed forward neural networks that can treat different types of data inputs either 2D images or 1D signals. In general, CNN consists of many layers namely, input layer, convolution layer, RELU layer, fully connected layer, classification layer, and output layer. CNN is basically based on two processes; convolution using a

trainable filter which has a pre-specified size, and weights that adjusted during the down sampling process in the training phase to achieve a high accuracy. In this research, the cropped and uncropped brain tumors images are stored as a database and three folders are created, each one consists of the images for specific class glioma, meningioma, and pituitary tumor. The database is partitioned into training and testing data, where 70% of the data is utilized in the training stage and the rest is used in the test stage. A new CNN architecture is employed in this paper. The next sections will explain the structure of the proposed CNN architecture. In this paper, we have proposed and used a newly designed CNN architecture. The architecture consists of 18 layers to enable the classifier to grade the brain tumor effectively. In this paper the architecture is modified and transferred to be applied on three different images dataset; cropped, uncropped, and segmented and the performance of the architecture was evaluated. Figure 2 illustrates the structure of the used CNN architecture.

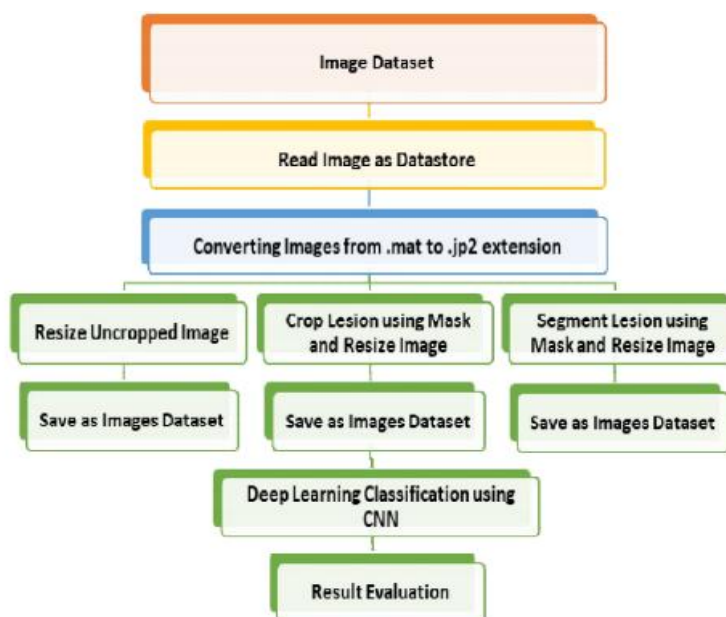

Figure 1: Block Diagram of the Proposed Methodology

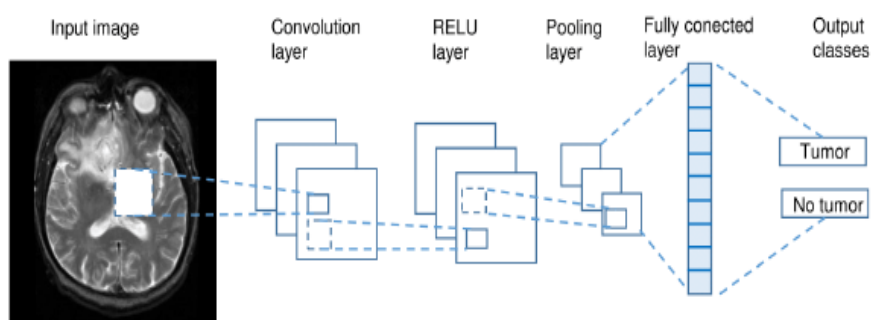

Figure 2: CNN approach.

The main aim and motivation behind this research paper are to provide a new CNN architecture for grading (classifying) brain tumors using T1-weighted contrast-enhanced brain MR images. Figure 1 Shows the Block diagram of the proposed methodology. In this section, the following sub-sections are discussed in detail, the used dataset, and the proposed methodology. To evaluate the performance of the proposed CNN architecture in grading the

brain tumor in both cases; cropped and uncropped image, the confusion matrix for all cases (cropped, uncropped, and segmented) were generated, and a comparison between the CNN architecture outputs with its corresponding original image label was carried out based on these generated confusion matrices. In general, using these generated confusion matrices we can calculate the accuracy, sensitivity, precision, and specificity, to measure how precisely the brain tumor being graded.

Convolution Layer: A convolution is defined as an operation on two functions. In image analysis, one function consists of input values (e.g. pixel values) at a position in the image, and the second function is a filter (or kernel); each can be represented as array of numbers. Computing the dot product between the two functions gives an output. The filter is then shifted to the next position in the image as defined by the stride length. The computation is repeated until the entire image is covered, producing a feature (or activation) map. This is a map of where the filter is strongly activated and ‘sees’ a feature such as a straight line, a dot, or a curved edge. Unlike some neural networks where every input neuron is connected to every output neuron in the subsequent layer, CNN neurons have sparse connections, meaning that only some inputs are connected to the next layer. By having a small, local receptive field (i.e., the area covered by the filter per stride), meaningful features can be gradually learnt, and the number of weights to be calculated can be drastically reduced, increasing the algorithm’s efficiency.

ReLU Layer: The ReLU layer is an activation function that sets negative input values to zero. This simplifies and accelerates calculations and training and helps to avoid the vanishing gradient problem. Mathematically it is defined as: $f(x) = \max(0, x)$. where x is the input to the neuron. Other activation functions include the sigmoid, tanh, leaky ReLUs, Randomized ReLUs and parametric ReLUs.

Pooling Layer: The Pooling layer is inserted between the Convolution and RELU layers to reduce the number of parameters to be calculated, as well as the size of the image (width and height, but not depth). Max-pooling is most used; other pooling layers include Average pooling and L2-normalization pooling. Max-pooling simply takes the largest input value within a filter and discards the other values; effectively it summarizes the strongest activations over a neighborhood. The rationale is that the relative location of a strongly activated feature to another is more important than its exact location.

Fully Connected Layer: The final layer in a CNN is the fully connected layer, meaning that every neuron in the preceding layer is connected to every neuron in the fully connected layer. Like the convolution, RELU and pooling layers, there can be 1 or more fully connected layers depending on the level of feature abstraction desired. This layer takes the output from the preceding layer (Convolutional, RELU or Pooling) as its input, and computes a probability score for classification into the different available classes. strongly activated features that would indicate the image belongs to a class. For example, on histology glass slides, cancer cells have a high DNA to cytoplasm ratio compared to normal cells. If features of DNA were strongly detected from the preceding layer, the CNN would be more likely to predict the presence of cancer cells. Standard neural network training methods with backpropagation and stochastic gradient descent help the CNN learn important associations from training images.

4. EXPERIMENTAL RESULTS

All experiments were executed using a desktop computer with Intel Core-I7 processor and 16 Gb RAM. Both image dataset cropped and uncropped were run with a minibatch size of 64, ADAM optimizer as optimizing method, and with learning initial rate of 10-3 which results in 1600 iterations. The dataset was divided into three subsets: training, validation, and testing with a percentage of 70%, 15%, and 15% respectively. The following sections report the results of the proposed two image datasets using the designed CNN architecture. Figure 3 shows the accuracy variation overtraining and validation process during the CNN training and Training and.

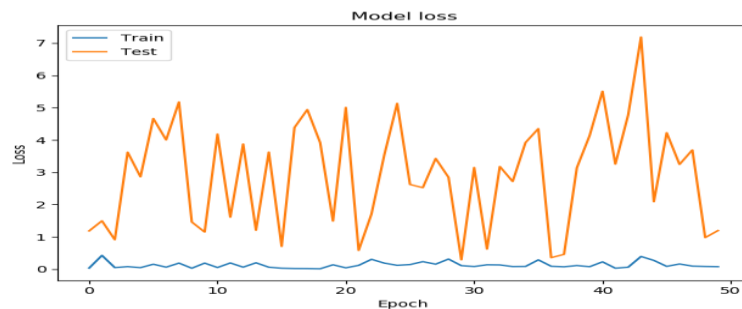



Figure 3: The Variation of Accuracy for Training and testing process

```
In [16]: import numpy as np
...: from keras.preprocessing import image
...: test_image = image.load_img('validationtest/brain_tumors.jpg', target_size = (64, 64))
...:
...: test_image
Out[16]:
```



```
In [20]: if result[0][0] == 0:
...:     prediction = 'Benign'
...: else:
...:     prediction = 'Malignent'
...:
...: print("Detected tumor type is %s"%prediction)
Detected tumor type is Malignent
```

Figure 4: detection and classification of tumor

The dataset that has been used in this paper contains three types of brain tumors; benign and Meningioma. In this work, an efficient automatic brain tumor classification is performed by using the proposed convolution neural network. Various manners have been applied to the dataset, such as segmented, cropped and uncropped tumors.

5. CONCLUSION

In this paper, we have presented a new convolutional neural network (CNN) architecture for automated grading (classification) of a brain tumor in three brain datasets: uncropped, cropped, and segmented region of interest (ROI). Our architecture succeeded in grading the brain tumor three classes with high performance in accuracy and sensitivity in all dataset cases: uncropped, cropped, and segmented. The system can significantly grade the tumor into

three levels: meningioma, and benign tumor using T1 weight contrast-enhanced brain MR images. This architecture grading efficiency may even be further improved by including more brain MR images with different weights and with various contrast enhancement techniques to allow the architecture to be potentially more generalized and robust application for larger image databases.

REFERENCES

- [1] WHO Statistics on Brain Cancer. Available online: <http://www.who.int/cancer/en/> (accessed on 1 July 2019).
- [2] International Agency for Research on Cancer. Available online: <https://gco.iarc.fr/> (accessed on 1 July 2019).
- [3] Brain Tumor Basics. Available online: <https://www.thebraintumourcharity.org/> (accessed on 1 July 2019).
- [4] American Cancer Society website. Available online: www.cancer.org/cancer.html (accessed on 1 July 2019).
- [5] Brain Tumor Diagnosis. Available online: <https://www.cancer.net/cancer-types/brain-tumor/diagnosis> (accessed on 1 July 2019).
- [6] Litjens, Geert, et al. A survey on deep learning in medical image analysis. *Medical image analysis*, Vol. 42, pp 60-88, 2017. DOI: 10.1016/j.media.2017.07.005.
- [7] S Tandel, Gopal, et al. A Review on a Deep Learning Perspective in Brain Cancer Classification. *Cancers*, Vol 11.1, 2019. DOI: 10.3390/cancers11010111.
- [8] Mohsen, Heba, et al. Classification using deep learning neural networks for brain tumors. *Future Computing and Informatics Journal*, Vol 3, pp 68-71, 2018. DOI: 10.1016/j.fcij.2017.12.001.
- [9] Sobhaninia, Zahra, et al. Brain Tumor Segmentation Using Deep Learning by Type Specific Sorting of Images. *arXiv preprint arXiv:1809.07786* (2018).
- [10] Widhiarso, Wijang, Yohannes Yohannes, and Cendy Prakarsah. Brain Tumor Classification Using Gray Level Co-occurrence Matrix and Convolutional Neural Network. *IJEIS (Indonesian Journal of Electronics and Instrumentation Systems)*, Vol 8, pp 179-190, 2018. DOI: 10.22146/ijeis.34713.
- [11] Chandra, Saroj Kumar, and Manish Kumar Bajpai. Effective algorithm for benign brain tumor detection using fractional calculus. *TENCON 2018-2018 IEEE Region 10 Conference. IEEE*, 2018. DOI: 10.1109/TENCON.2018.8650163.
- [12] Seetha, J., and S. S. Raja. Brain Tumor Classification Using Convolutional Neural Networks. *Biomedical & Pharmacology Journal*, Vol 11, pp 1457-1461, 2018. DOI: 10.1007/978-981-10-9035-6_33.
- [13] Cheng, Jun, et al. Enhanced performance of brain tumor classification via tumor region augmentation and partition. *PloS one*, Vol 10, 2015. DOI: 10.1371/journal.pone.0140381.